

TAPIMATIC

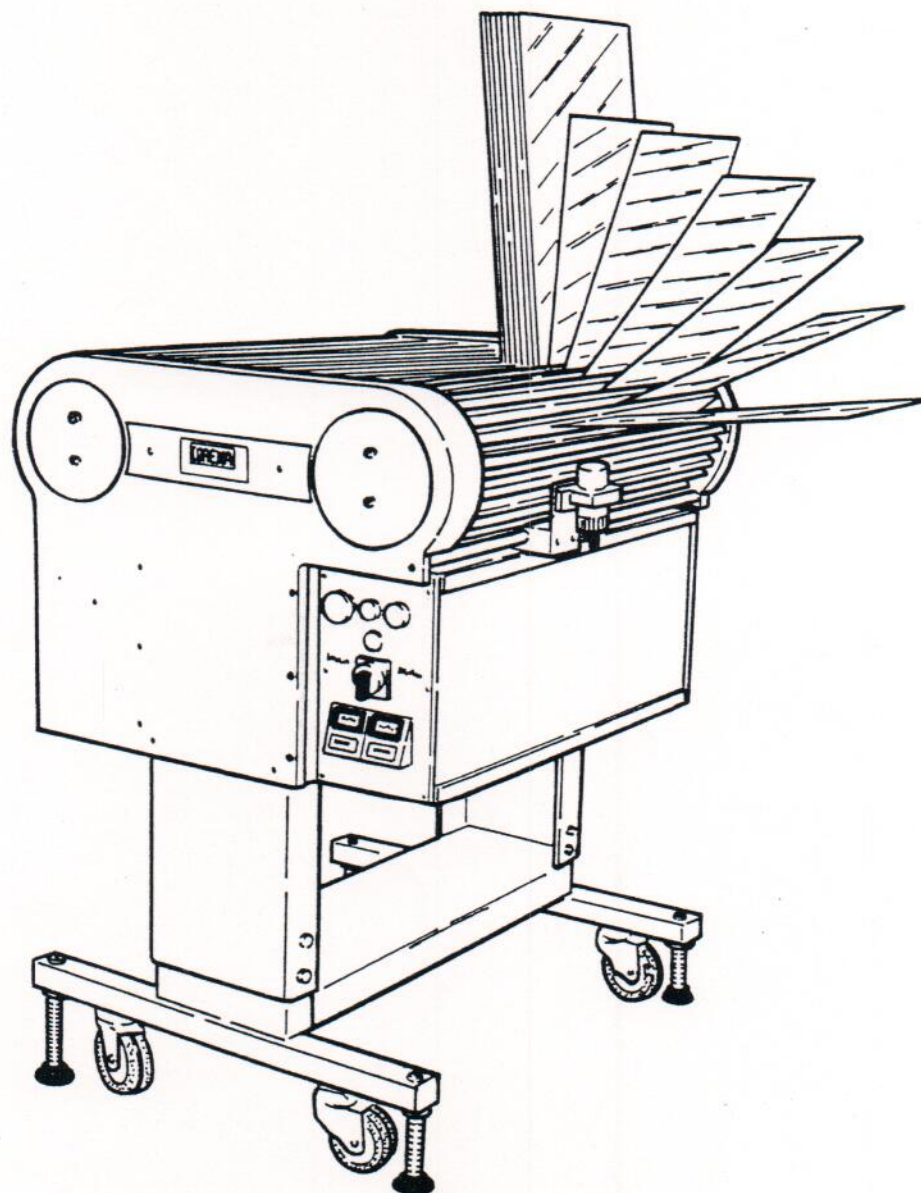

ETS **COREMA** SA.
Conception et Réalisation de machines

3 rue Gaspard Monge, 93600 AULNAY-S/Bois, FRANCE

☎ (33) 1 48.66.77.44

Fax. (33) 1 48.66.53.79

INSTRUCTIONS MANUAL

TAPIMATIC CD 50

CLIENT

ORDER NO

SERIAL NO

VOLTAGE

DIMENSIONS

IDENTITE DE LA MACHINE	
TAPIMATIC	
TYPE	CD 50 R 24
SERIAL NUMBER	
DIMENSIONS	LONGUEUR 720 MM LARGEUR 740 MM HAUTEUR 910 MM
WEIGHT	125 KG
WORKING WIDTH	610
MOTOREDUCTOR	SIREM R1C 225 H12B/f 4,5 T/MN
SENSOR	OMRON E2K C25 MY1
TIMER QTY 2	OMRON H3CAA
MOTOR SPROCKET	12 TEETH 3/8
DRIVING SPROCKET	60 TEETH 3/8 SIMPLE
OPTION	ALU ROLLERS
VOLTAGE - FREQUENCY	220 V - 50 HZ
WIRING DRAWING	14837 A3
CUSTOMER	PRINTEL
COUNTRY	PAYS BAS

SUMMARY

GENERAL DESCRIPTION AND TECHNICAL SPECIFICATIONS

MAIN DESCRIPTION

- Chassis
- PVC part
- Castors

INSTALLATION

- a. Setting procedure
- b. Electric connections

STARTING UP

- a. Feeder version
 - V adjustment
 - Timer set up
- b. Collector version
 - V adjustment
 - Timer set up

SPECIAL ADJUSTMENTS

FUNCTIONING DEFECTS

- a. Feeder version
- b. Collection version

MAINTENANCE

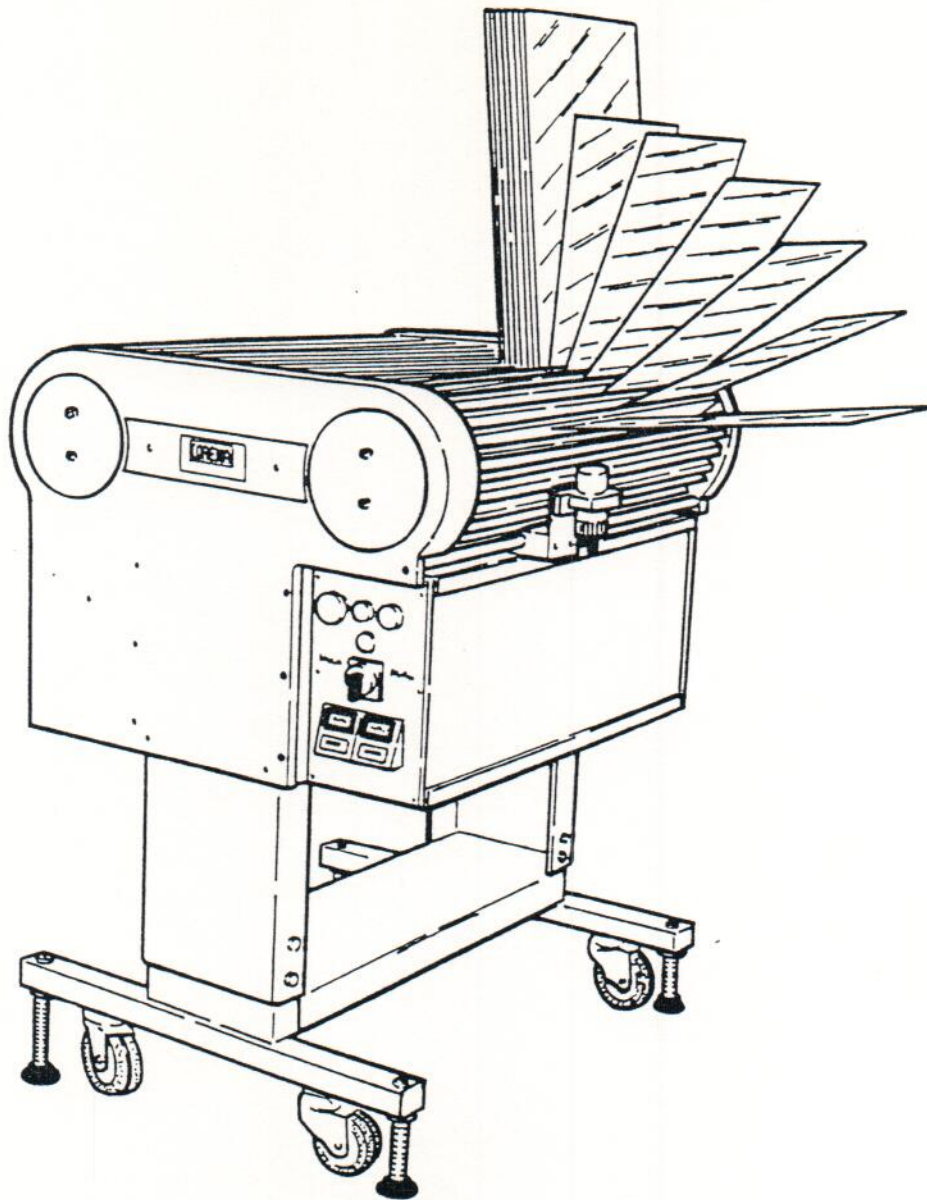

GENERAL DESCRIPTION AND TECHNICAL SPECIFICATIONS :

The Tapimatic following its version is used for Loading, or for loading and unloading the pcbs and is available in 610mm "24" and 760mm "30" meanwhile 1016 "40" Tapimatic is delivered on special requests.

Tapimatic C is used as Loader while **Tapimatic CD** as loader/unloader in TR "Transfer" and R." Reversible".

MAIN DESCRIPTION :

The machine constitutes :

A CHASSIS

Black metallic chassis made in two parts as shown in the exploded view :

1. Down part including the footing with height adjustment screws and two metallic bearers (10035 A3) right and left side.
2. Upper black mettalic part (10036 A4)called cheeks which is fixed on the down part and allows manual height adjustment of about 300mm (telescopic foot) with the help of height adjustment screws (10083 A3).

B. WHITE PVC PART

It's the main upper part equipped with belt and slats having 4.5mm gap.

C. CASTORS

Most of the Tapimatic are delivered with castors and height adjustment screws (10083 A3).

In option, The Tapimatic can be delivered with bigger castors mounted on the screws (for easy displacement of Tapimatic with pcbs from one machine to the other).

The Tapimatic exists in two versions :

1. **TRANSFER**
Collecting from one side and feeding from other side (change of pcb face)
2. **REVERSIBLE**
Collecting and feeding from the same side.

INSTALLATION :

a. Setting procedure :

Never raise the machine by holding the slats.

The Tapimatic is delivered bolted on a pallet with a pvc film around for protection against transport blows and dust.

Control outside packing and make reserves if necessary.

Install the machine at its working place. The Tapimatic can only be "Feeder" C or "Feeder/Collector" **CD**.

Security valve (anti-jam device) must always be to the side of the machine to be fed.

Proceed to height adjustment as follows :

The Tapimatic is installed next to the machine to be fed.

Place **PVC adjusting L**(supplied with the machine) on the slats (handle on the slats and the top of this **L** going down wards on the slats). The Tapimatic will be on the right height when top side of the **PVC L** will stay over the machine to be fed (see drawing n° 11861 A4) and until you don't get this right height adjustment go on setting the height with height adjustment screws

Check machine's horizontality from all sides and block the screws with nuts.

b : Electric connections

Connect to single phase 220 volts.

The Tapimatic is ready to run.

Important note :

The conveyors of the machine to be fed must be enough long so that bigger size pcbs be placed otherwise **additional conveyor TAP CVV** sold in option must be planned.

STARTING UP :

Just check Control board position. It can be fixed either to the right or to the left side passing whole control board plate from inside to the side wanted .

Select Feeder or Loader mode (3 position commutator on control panel) The timer is operational if time is in seconds and the work mode on 1 (see timer notice).

IN COLLECTOR MODE :

The Tapimatic has been positioned as described here above.

The pcb detector must be between the Tapimatic and the machine to be fed.

Check that pcb detector is about 10mm down to the pcb passage.

Check position of the V created by two pvc slats (the gap between two slats making the form of V is called V). The pcb must enter into the V while down slat is completely horizontal so that the pcb pick up takes place on full angle (18°).

Adjustment of V position :

V position can be changed adjusting contact position in front of the coder cog wheel (10057 A4)

Loosen blocking screw (10061 A4) and turn slightly the contact support (11702) in a way to shift the wheel of micro contact from coder cog wheel notch.

Check inferior slat of the V and start again if necessary.

COLLECTOR MODE TIMER SET UP

This timer assures rise control. It must only allow passing distance between detector and V depth. This time delay can slightly be increased to let askew pcb get aligned in the V before rising (if needed set timer on 0.1 seconds instead of 1 second to be more precise).

IN FEEDER MODE :

The security valve (anti-jam device) must always be to the side of the machine to be fed. Be carefull that the Tapimatic is not too near to the machine to be fed otherwise the security valve will not be able to operate. Once the Tapimatic aligned heightwise, place 3 position commutator on **Feeder** mode. Control that **feeder** is well in working mode **A** and timing in seconds. Press on any time say **20 seconds** and start the cycle pressing on **START** switch. The count down begins and activates the indexation motor when its on zero. The belt moves a bit and the pcb is taken by the conveyors of the machine to be fed. Note the time so that first pcb be at the needed distance for putting the second one on and for that increase the time (check timer notice). The right time selection comes quickly with a little bit experience and this time selection depends on the speed of the conveyor and on the pcb length.

V ADJUSTMENT

V does not need to be refined for medium or short pcbs. In some cases when pcbs are long and heavy, one must be sure that the second pcb does not touch the one which is on the feed conveyor. This may occur if the pcb is slightly flexible (less than 1.6 or long and narrow) so control V position and adjust (as explained for collector mode) in a way that the angle between the flow direction and following slat be the maximum say maximum 18°.

SPECIAL ADJUSTMENTS :

FOR SLANTWISE ENTRY

It may be needed that the pcbs enter slantwise in the machine to be fed. It's possible and for this just need to put the Tapimatic higher from one side (adjust with adjusting wheels and block).

FOR FEEDING NOT TOO FINE PCBS : double or multiple indexation

In this case one interior timer is added for allowing to index one, two or more angles. This subterfuge is used when pcbs are more flexible than rigid ones but are not too fine. This double or multiple indexation helps to avoid purchase of a CDS (Tapimatic for flexible pcbs).

ADDITIONAL CONVEYOR TAP CVV :

This conveyor, needed either in entry or in exit, is to be fixed at the place of the round mouldings which are to be taken away. The conveyor speed which is variable and adjustable can be adjusted by means of a potentiometer situated on the Tapimatic control board.

FUNCTIONING DEFECTS :

a. FEEDER VERSION

After power on and "start" the green indicator remains off :

Check :

Emergency control switch (may be is clicked)
Security control board (may be blocked).

The indicator is on but belt does not work :

Check :

Commutator position : It must be on "Feeder".

The timer "feeder" is not in working mode " A " or the time selection is on " hours ". control and correct.

The first pcb leaves and second one falls over :

Check :

Time selection printed on the timer which must be in **Seconds**, following conveyor speed and the pcbs length ,make it a bit longer.

Indexation contact is loose (10061 A4). Tighten it and put it at the right position.

The break of the motor which may be defective so needs to be changed.

The pcb comes on the conveyor to be fed but does not leave from the V :

Check :

The Tapimatic height using height adjustment screws.

Front and back side level : The pcb is touching just the one roller of the machine. V bottom side is too high so the grip is too feeble for taking out the pcb.

b. COLLECTOR VERSION :

The pcb enters in the V but the belt does not rise :

Check :

The commutator position and it must be on COLLECTOR

The pcb does not rise :

Check :

The timer function it must be in mode " A " and time selection in " seconds "

The pcb still does not rise :

Check :

The detector. The count down must start as the pcb comes over vertically if still there is not count down then check the OMRON detector with one finger.

Obturate the detector and control that the red led is lighted (cord side). If still there is no light then control the connections and change if needed.

The led is on so the detector is operational but does not detect after a while :

Check :

Its detection height. If the distance is too big, modify the sensibility (consult the notice and use the screw delivered with the machine) The right sensibility is the one which will detect the pcb at 15mm distance from the detector and in detector axis. Adjust the height at 15mm and let the pcb enter.

NOTE : too high sensibility may lead to two defects :

Continuous detection of machine's element (roller, or any corner).

OR previously lifted pcb leading to continuous rotational movement.

ADDITIONAL CONVEYOR TAP CVV :

The conveyor does not work after power on :

Check :

Potentiometer position and set far from zero.

The motor does not run :

Check :

Power supply at motor infeed : 24 volts CC.

Carbon brushes if there is voltage in terminal

Voltage at speed control board infeed and if there is, control the fuses.

MAINTENANCE :

There is no special maintenance except changing from time to time the motor brushes of indexation.

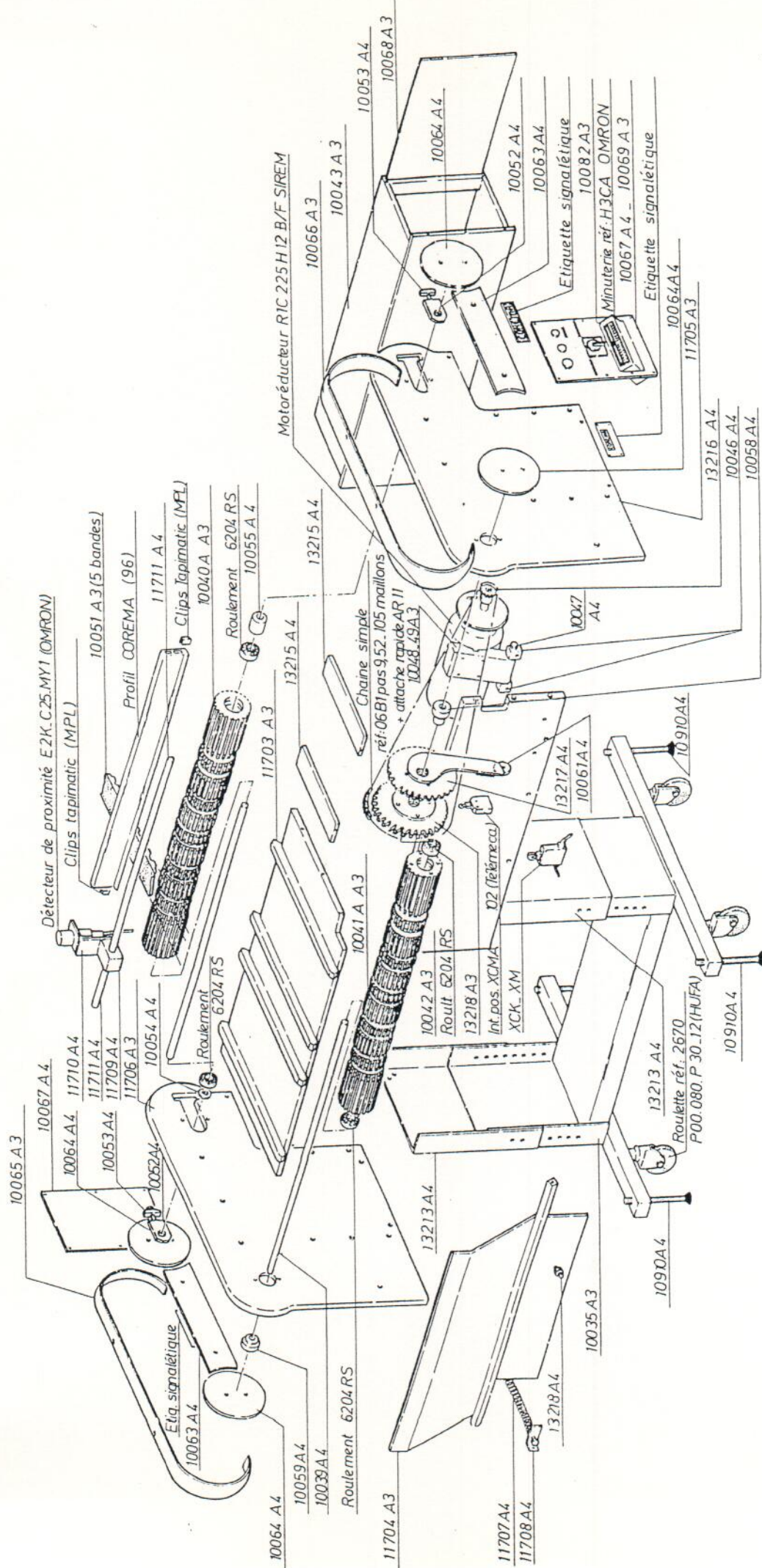

B	MISE A JOUR	25.11.93
A	MISE A JOUR	1-7-92
Indice	Modifications	Date
Dessiné: <i>EKS</i>	Matière :	
Vérifié :	Quantité :	
Date : 9.1.1991	Traitement :	
Ech.: 1/1		
Tot. Gén.: J 10 / 113		
TAPIMATIC CD 50		Indice
COREMA		N° 11712 A3
3 Rue Gaspard MONGE 93600 AULNAY SOUS BOIS		B

Roue codeuse
Cog wheel

Interrupteur de position
Index limit switch (Télémechanique) XCMA 102.2
Dispositif d'ajustement V ang.
Position adjustment device

Distance 10 / 12 mm
Adjustment distance 10 / 12mm

Circuit
Circuit

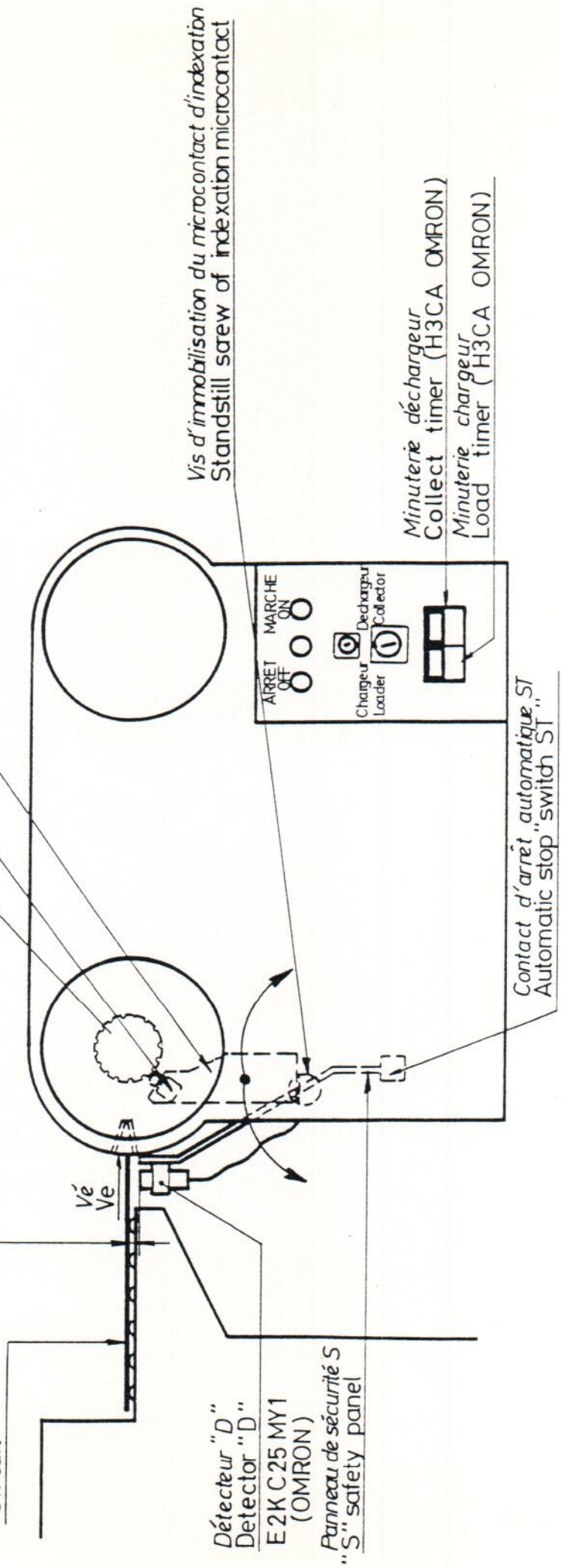

Vis d'immobilisation du microcontact d'indexation
Standstill screw of indexation microcontact

Minuterie déchargeur
Collect timer (H3CA OMRON)

Minuterie chargeur
Load timer (H3CA OMRON)

Contact d'arrêt automatique ST
Automatic stop "switch ST"

Détecteur "D"
Detector "D"
E2K C25 MY1
(OMRON)

Panneau de sécurité S
"S" safety panel

TAPIMATIC REVERSIBLE

REVERSE TAPIMATIC

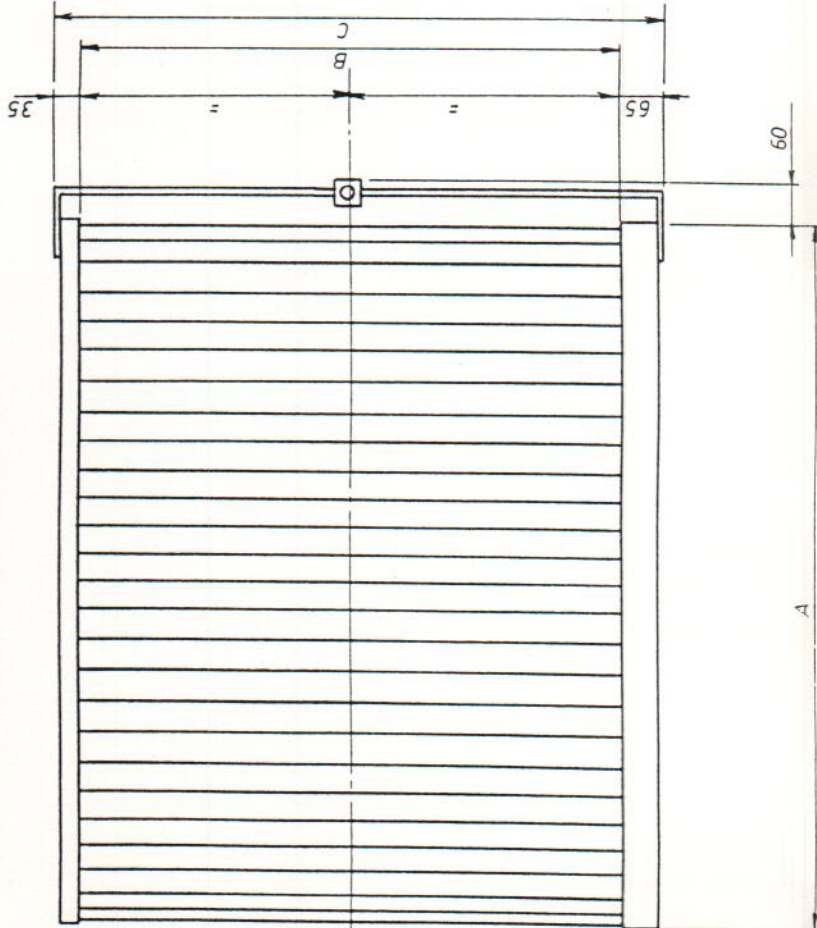
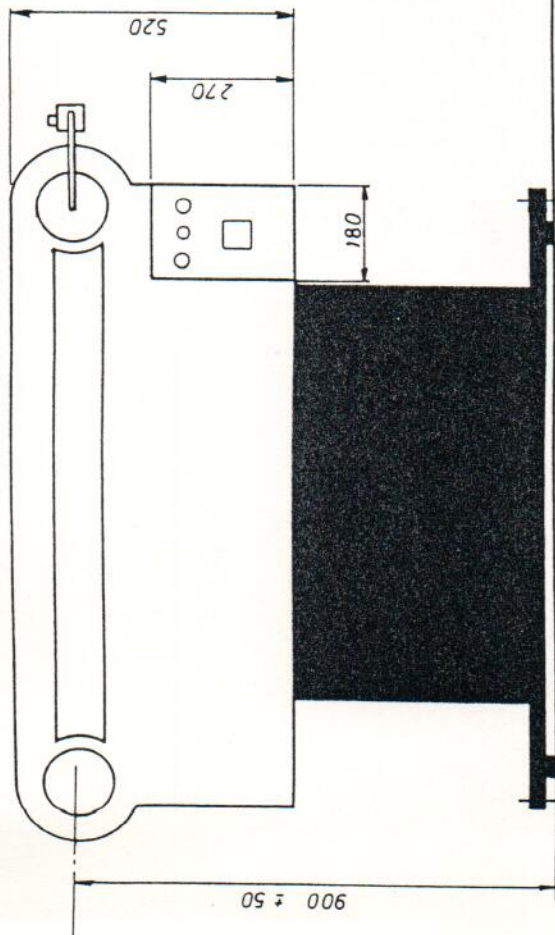

CD 25	24"	30"	40"
A	415	415	415
B	620	765	1020
C	720	870	1120

CD 50	24"	30"	40"
A	690	690	690
B	620	765	1020
C	720	870	1120

CD 100	24"	30"	40"
A	1330	1330	1330
B	620	765	1020
C	720	870	1120

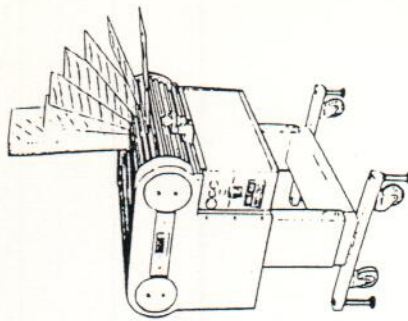

TAPIMATIC

Indice	Modifications	Date
Dessiné : <i>flc</i>		
Vérifié :		
Date : 24.9.91		
Ech. : 1/10		
Tel. Gén. : J.13 / J.13		
Matière :		
Quantité :		
Traitement :		
OVERALL DIMENSIONS		
Encadrements Tapimatic		
COREMA		
3 Rue Gaspard MONGE		
93800 AULNAY SOUS BOIS		
N° 12291		
Indice A3		

V22 ED 01 + 231E01 (BACO)

V10 SA 20 + 231ECHG (BACO)

V22 AA 03 + 231E 10 (BACO)

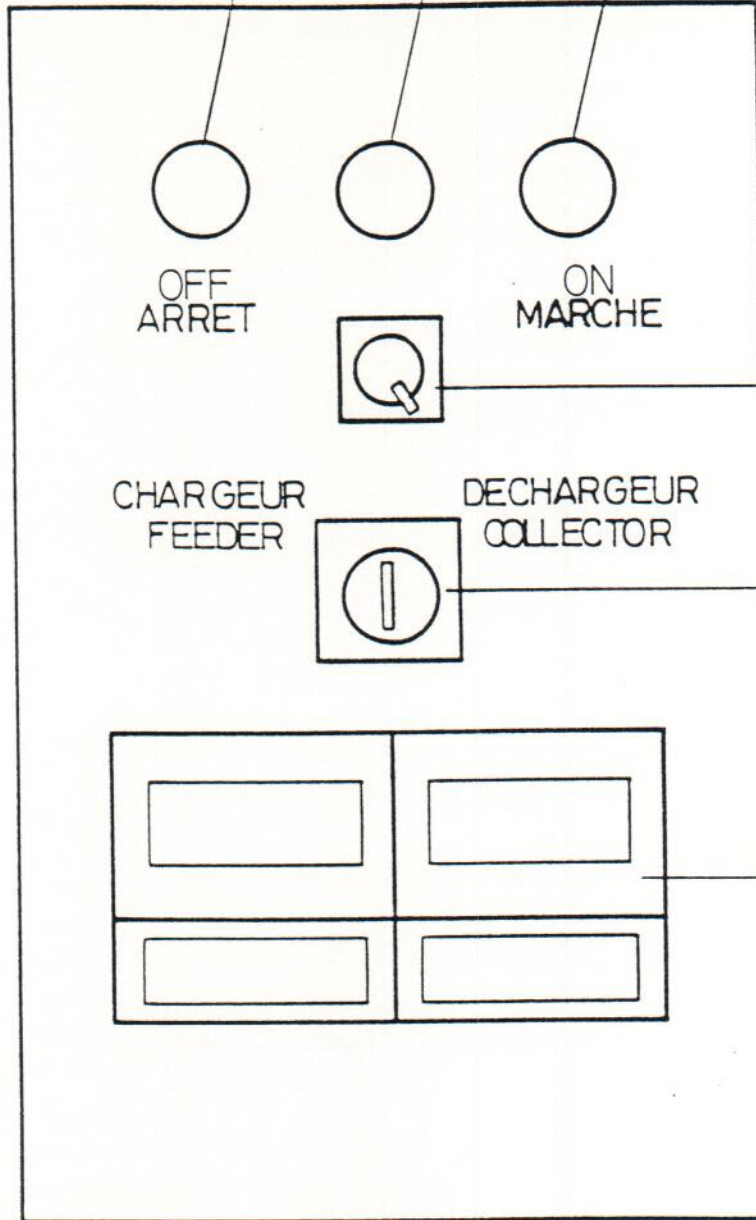

POTENTIOMETER
DELIVERED WITH SPEED
CONTROL BOARD VBT
24 A (SEDEG)

*Potentiomètre livré avec
platine VBT 24A (SEDEG)*

COMMUTATOR
*Commutateur (BACO)
PR12_2202 - Transfer.
PR12_69041 - Revers.*

2 TIMERS
*2 Minuterics (OMRON)
H3 CA*

FACE AVANT TAPIMATIC
FRONT SIDE TAPIMATIC

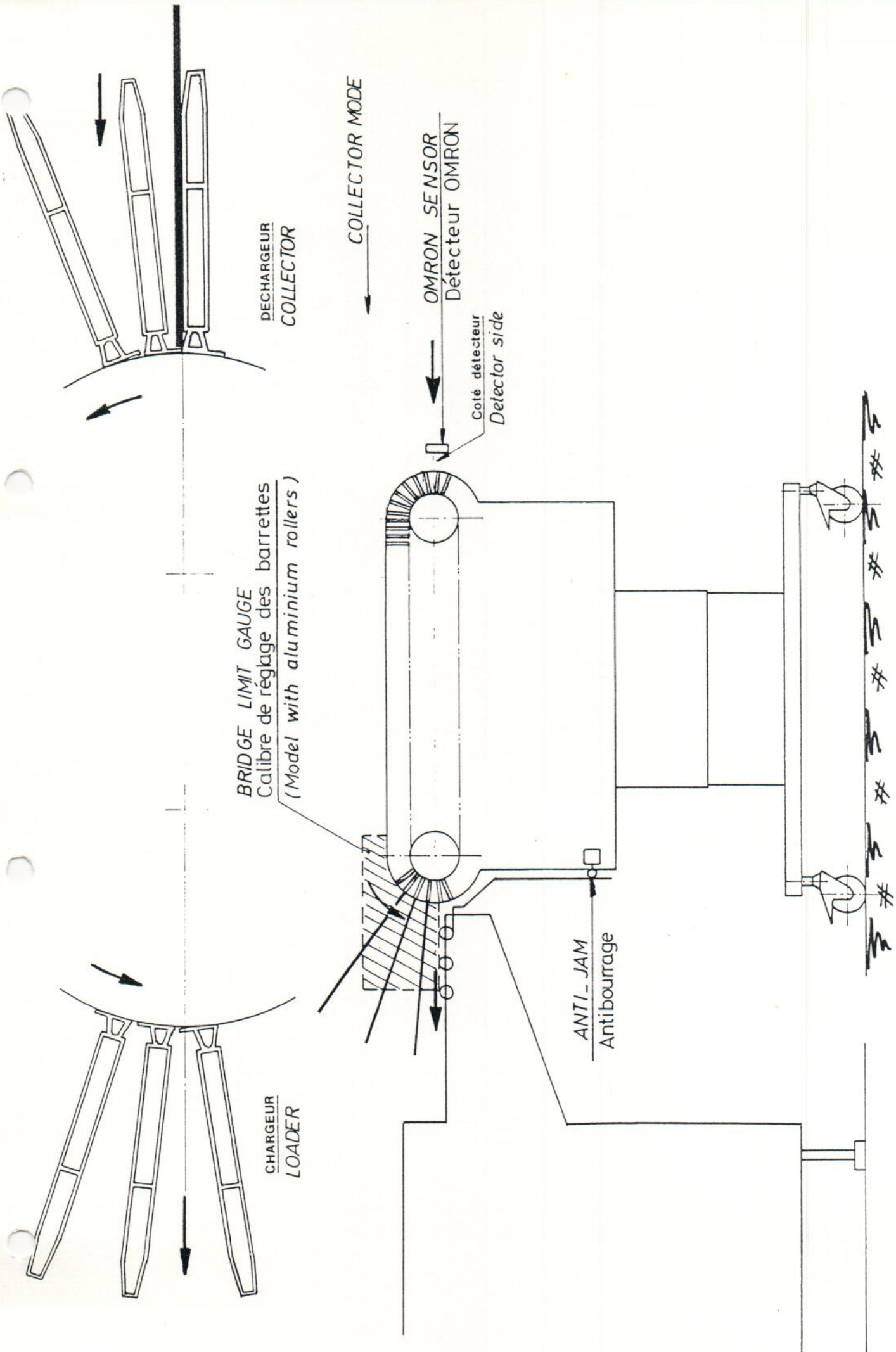

CALIBER
Calibre de réglage des barrettes
(Model with aluminium rollers)

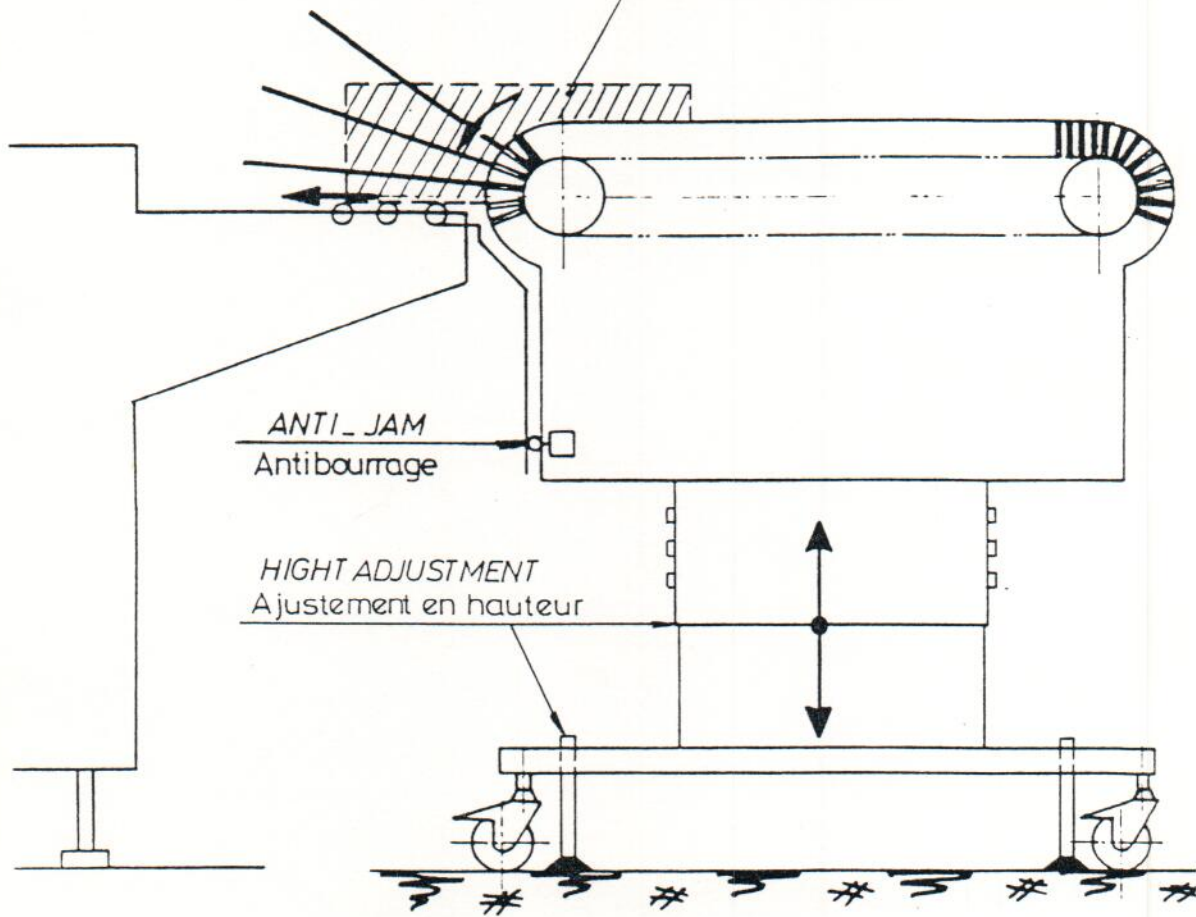

CUSTOMER NAME: PRINTEL MACHINE TYPE: TAPIMATIC C.D.S.O.R
 PURCHASE ORDER: 41116340 DELIVERY DATE: 11-94
 DATE:

COREMA 3 Rue Gaspard MONGE
 93000 AULNAY SOUS BOIS
 Ce document est la propriété de COREMA -
 Il ne peut être reproduit en tout ou en partie ni
 communiqué à des tiers sans son autorisation écrite

MECHANICAL PARTS LIST

Drawing	N° item	Nb for 1 machine	Item identification	Total nb of machines	Recom. ded spares parts	Comments
1	11712 A3					
2	10039 A4	2	SHAFT			
3			Arbre lg: 718 mm			
4	10040A A3	1	DRIVEN ROLLER			
5			Rouleau libre aluminium pas 12,7-21 dents			
6	10041A A3	1	DRIVE ROLLER			
7			Rouleau moteur aluminium pas 12,7-21 dents			
8						
9		*	VERSION FOR ROLLER PVC			
10	* 10040C A3	1	DRIVEN ROLLER			
11			Rouleau cannelé recepleur			
12	* 10041C A3	1	DRIVE ROLLER			
13			Rouleau cannelé moteur			
14						
15	10050 A4	1	MAIN SPOCKET			
16			Pignon moteur pas 9,5-12 dents			
17	10054 A4	1	DISK			
18			Rondelle			
19	10056 A3	1	ON CODDER COG WHEEL 24 TOOTH			
20			Roue de commande 24 dents			
21	10057A4	1	DRAWING DISK			
22			Disque d'entraînement 60 dents pas 9,5			
23	11702 A4	1	SUPPORT OF ADJUSTER (CONTACTOR)			
24			Support de réglage du contacteur			
25	10062 A4	1	CONTACTOR			
26			Contacteur			
27	10065 A3	1	MOULDING			
28			Enjoliveur			
29	10066 A3	1	DRIVING SIDE MOULDING			
30			Enjoliveur cote entrainement			

COREMA
 3 Rue Gerberd MONGE
 93600 AULNAY SOUS BOIS

Ce document est la propriété de **COREMA** -
 Il ne peut être reproduit en tout ou en partie ni
 communiqué à des tiers sans son autorisation écrite

CUSTOMER NAME: P.R.I.N.T.E.R. MACHINE TYPE: TAPIMATIC C.A.S.O.R.
 PURCHASE ORDER: 4.111.6340 DELIVERY DATE: 1.1.94
 DATE:

MECHANICAL PARTS LIST

Drawing	N° item	Nb for 1 machine	Item identification	Total nb of machines	Recom. ded spares parts	Comments
1	11704 A 3	1	ANTI JAM SWITCH + DETECTOR SUPPORT			
2			Volet de securite et support detecteur			
3		1	MOTOREDUCTOR SIREM R1C225H12 B/F 4,5 Rpm			
4			Motoreducteur type R1C225H12 B/F 4,5 tr/mn			
5		1	12 TOOTH SIMPLE SPOCKET			
6			Pignon simple 12 dents pas 9,52 réf: PCR 06 B. Z12A			
7		1	SIMPLE CHAIN PITCH 9,52 - 105 LINKS			
8			Chaîne simple pas 9,52_ref: 06 B1. 105 maillons			
9		1	RAPID ATTACH			
10			Attache rapide AR 11			
11		1	DISK 60 TOOTH PITCH 9,52			
12			Disque 60 dents pas 9,52 DCR 06 B1_60			
13		4	BEARING			
14			Roulement 6204 RS			
15						
16						
17						
18						
19						
20						
21						
22						
23						
24						
25						
26						
27						
28						
29						
30						

COREMA
 3 Rue Gaspard MONGE
 93600 AULNAY SOUS BOIS

Ce document est la propriété de COREMA -
 Il ne peut être reproduit en tout ou en partie ni
 communiqué à des tiers sans son autorisation écrite.

CUSTOMER NAME: PRINTEL MACHIN TYPE: TAPIMATIC C.D.S.O.R.
 PURCHASE ORDER: 41116340 DELIVERY DATE: 11-94
 DATE: ELECTRICAL PARTS LIST

Drawing	N° item	Nb for 1 machine	Item identification	Total nb of machines	Recom. ded spares parts	Comments
1		1	MODE SELECTOR (COMMUTATOR)			
2			Interrupteur de position XCM TELEMECANIQUE			
3		1	MODE SELECTION (COMMUTATOR)			
4			Interrupteur de position XCK_XM TELEMECANIQUE			
5		1	PCB DETECTOR (PROXIMITY DETECTOR)			
6			Detecteur de proximité E 2K C25 MY 1 OMRON			
7			avec equerre en L			
8		2	TIMER OMRON H 3CA			
9			TIMER OMRON H 3CA			
10						
11						
12						
13						
14						
15						
16						
17						
18						
19						
20						
21						
22						
23						
24						
25						
26						
27						
28						
29						
30						

TYPE H

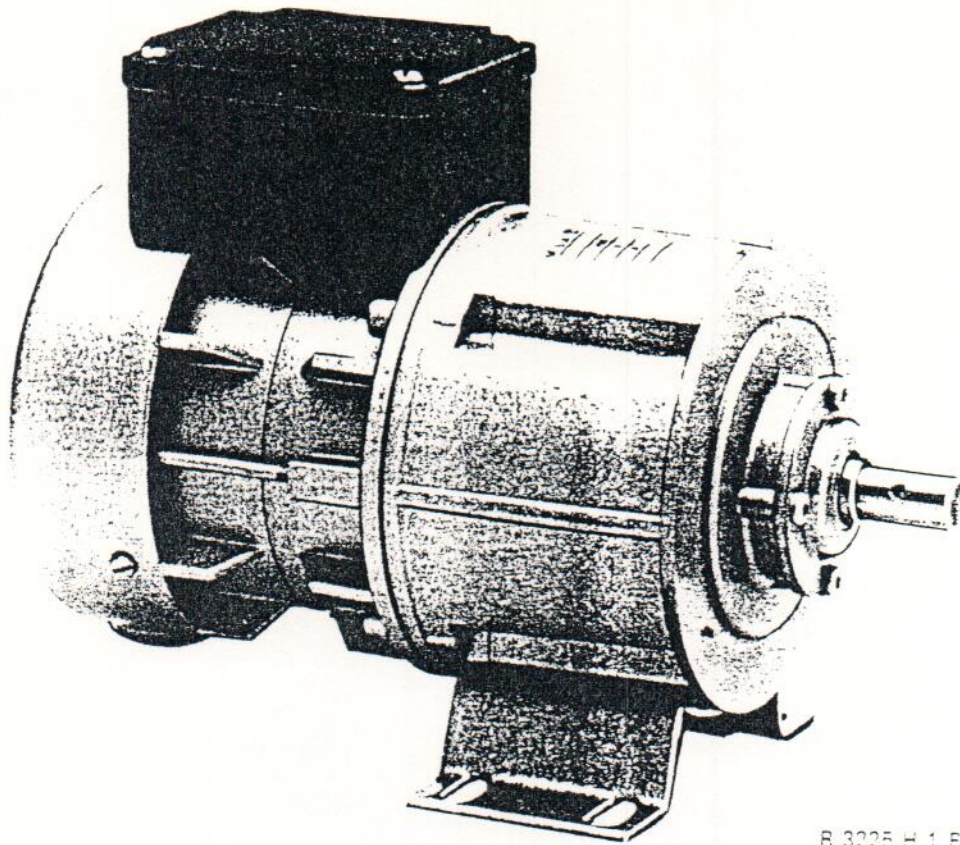

R 3225 H 1 E

MOTEUR deux sens de rotation.

Monophasé à condensateur permanent, ou triphasé.

MOTOR bi-directed MOTOR either.

Single phase with permanent capacitor or three phase.

MOTOR mit 2 Drehrichtungen.

Einphasig, mit Dauer-Kondensator oder für Drehstrom.

MOTORE a due sensi di rotazione.

Monofase con condensatore permanente, oppure trifase.

MOTOR dos sentidos de rotación.

Monofasico condensador permanente a trifasico.

Sireem	Pôles	Monophasé à condensateur 220 V-50 Hz	Triphasé 220/380 V 50 Hz	Couple nominal cm.N	Puissance utile W	Vitesse n1 tr/mn	Intensité sous 220 V A	$\frac{I_A}{I_N}$	$\frac{C_d}{C_N}$	Cos ϕ
1C 625	6	•		13,4	12	870	0,35	1,1	1,31	0,99
3 625			•	14,5	13	870	0,31	1,48	2,1	0,67
1C 425	4	•		25,8	36,5	1350	0,53	1,34	0,85	0,99
3 425			•	25,5	37	1400	0,23	2	1,9	0,65
1C 225	2	•		12,2	35	2700	0,45	1,67	1,41	0,99
3 225			•	14,2	40	2700	0,28	2,45	0,97	0,82

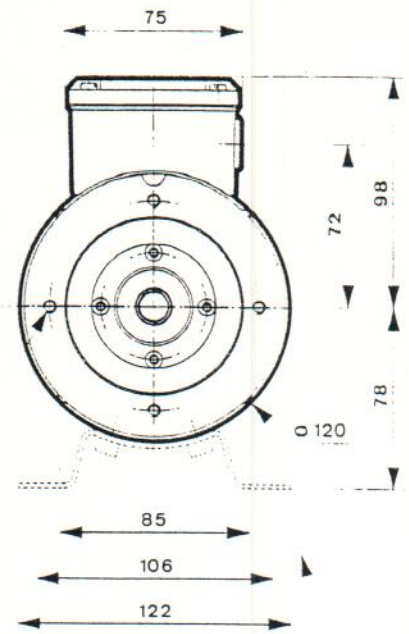
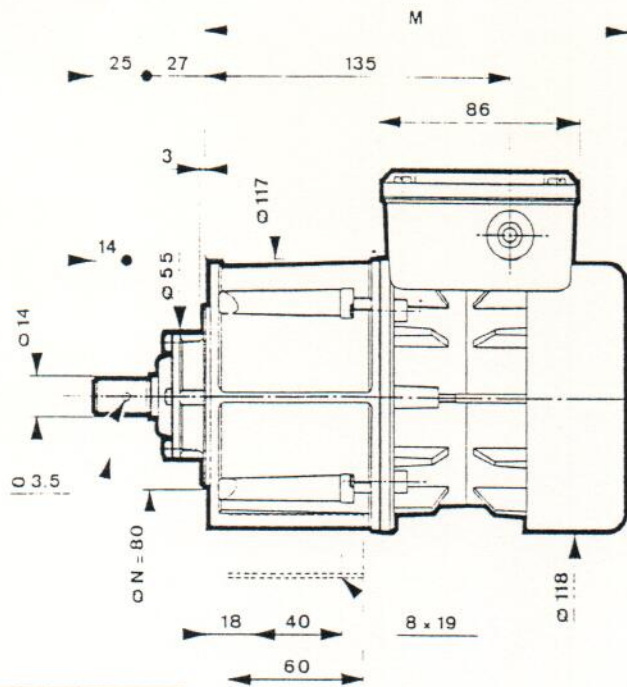

Sur demande
avec clavette

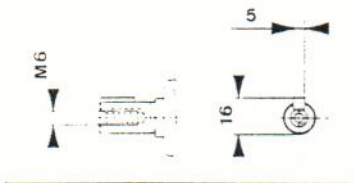

Positions de la
BOITE A BORNES

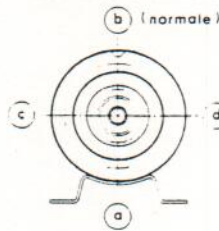

FIXATION « 2 »
par 4 trous M6
à 90° sur Ø 94
centrage sur Ø N

FIXATION « 1 »
avec patte

Sirem		Vitesse n ₂ tr/mn	Rapport de réduction n ₂ /n ₁	Couple nominal m.daN ⁽¹⁾		Charges maxi sur l'arbre lent		Cote M	kg
						Radiale ⁽²⁾ daN	Axiale daN		
R 1C 625 HB	R 3 625 HB	1,5	1/547	3,5*	3,5*	100	105	184	3
R 1C 425 HB	R 3 425 HB	2,3	1/547	3,5*	3,5*	100	105		
		3,5	1/390	3*	3*	100	105		
R 1C 225 HB	R 3 225 HB	4,5	1/547	3,5*	3,5*	100	105		
		7	1/390	3	3*	100	92		
R 1C 425 HB	R 3 425 HB	10,5	1/134	1,5*	1,5*	92	80		
		15	1/184	1,4	1,6	82	70		
		21	1/134	1,15	1,3	74	60		
R 1C 225 HB	R 3 225 HB	30	1/96	0,82	0,95	64	50		
		39	1/72	0,61	0,7	60	46		
		48	1/59	0,50	0,59	56	42		
		65	1/45	0,38	0,45	50	36		
R 1C 425 HB	R 3 425 HB	100	1/14	0,20*	0,20*	44	30		
R 1C 225 HB	R 3 225 HB	125	1/22	0,21	0,25	41	27		
		200	1/14	0,14	0,16	35	23		

1) daN = 1 kgF. (2) Appliquée au milieu du bout d'arbre. * Couple maxi à ne pas dépasser (moteur surpuissant pour ce rapport).

H3CA — Minuterie électronique multigamme

OMRON

- Alimentation en courant alternatif ou continu (24 à 240 V c.a./12 à 240 V c.c.)
- 8 modes de fonctionnement
- Temporisation de 0,1 sec à 9990 heures
- Affichage du temps écoulé par cristaux liquides
- 4 commandes extérieures disponibles.

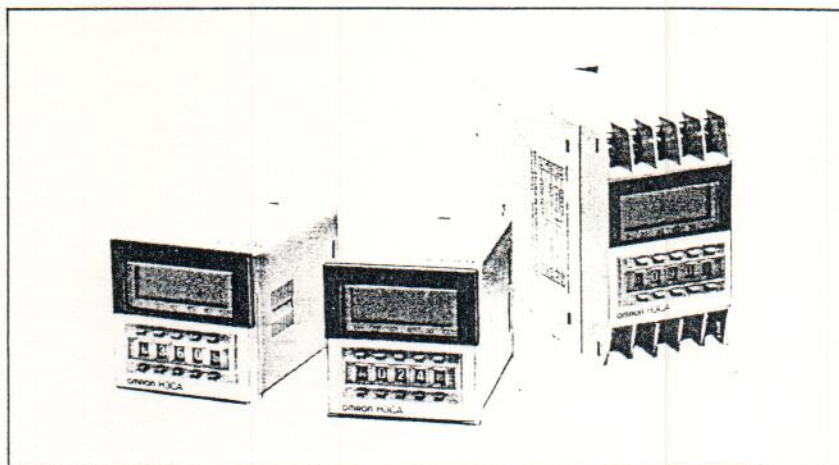

Caractéristiques techniques

Alimentation :
24 à 240 V c.a. 50/60 Hz, 12 à 240 V c.c.
(± 10 %)

Puissance consommée :
3 VA/3 W max

Sortie :
Relais 1 inverseur 250 V c.a.
pouvoir de coupure 3 A cos φ = 1

Répétitivité :
± 0,3 % ± 0,05 sec

Erreur d'affichage :
± 0,5 % ± 0,05 sec

Temps de réarmement :
0,5 sec max

Caractéristiques générales

Résistance d'isolement :
100 MΩ min (sous 500 V c.c.)

Rigidité diélectrique :
2000 V c.a., 50/60 Hz pendant 1 min.
(entre bornes et boîtier)
2000 V c.a., 50/60 Hz pendant 1 min.
(entre contact et circuit électronique)

1000 V c.a. 50/60 Hz pendant 1 min.
(entre contacts)

Résistance aux vibrations :
mécanique : 10 à 55 Hz, 0,75 mm en double amplitude
en fonctionnement 10 à 55 Hz ;
0,5 mm en double amplitude.

Résistance aux chocs :
mécanique : 1000 m/s² (100 G env.)
en fonctionnement : 100 m/s² (10 G env.)

Température ambiante :
- 10 à 55 °C

Humidité ambiante :
35 à 85 % RH

Durée de vie :
mécanique : 10 X 10⁶ manœuvres mini (sans charge à une fréquence de fonctionnement de 1800 manœuvres/heure)

électrique : 100 000 manœuvres mini (sous 250 V c.a. 3A φ = 1 à une fréquence de fonctionnement de 1800 manœuvres/heure.

Poids :
H3CA - A : 110 g env.
H3CA - FA : 190 g env.

Dimensions (mm)

● H3CA-A

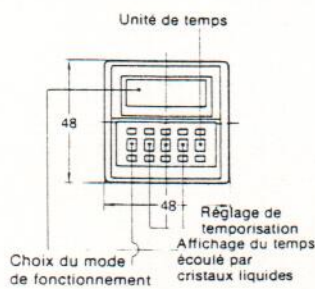
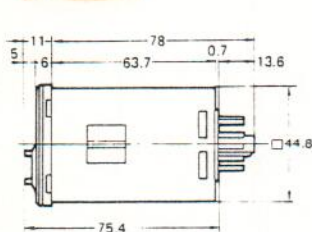

Découpes

Pour une minuterie

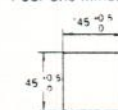

Pour deux minuterie

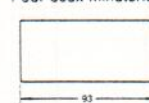

● H3CA-FA

Affichage du temps écoulé par cristaux liquides

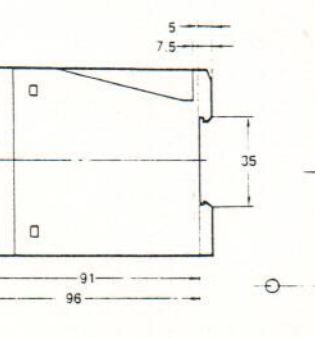
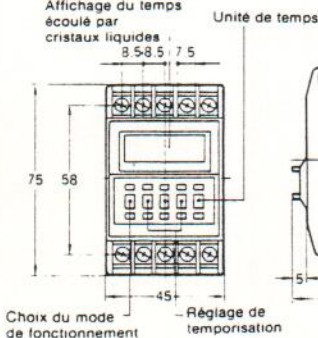

Découpes

2-M4 ou 4.5 dia.

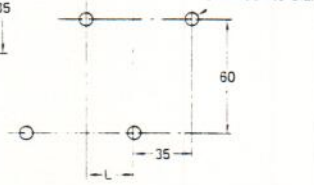

Gammes de temporisations

Plage de temporisation	Unité de temps	Unité de temps								
		0.1 s (sec)	s (sec)	0.1 m (min)	m (min)	0.1 h (hr)	h (hr)	10 h (10 hr)		
1 à 999 (3 digits)		0	0	1	0.1 S	à	9	9	9	10 h

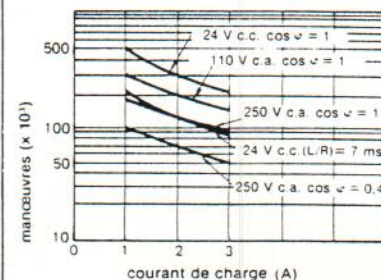

Huit modes de fonctionnement

Mode A - Retard à la mise sous tension

● Commande par signal

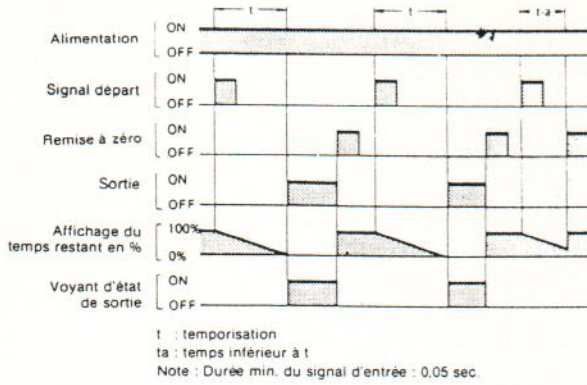

● Commande par tension d'alimentation

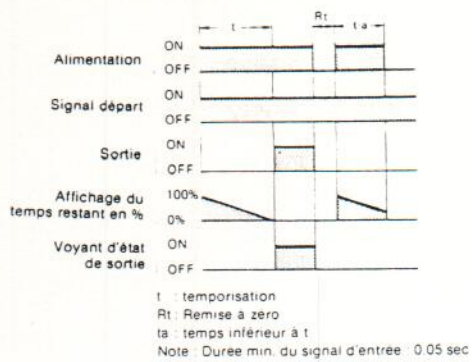

Mode B - Clignotant

● Commande par signal

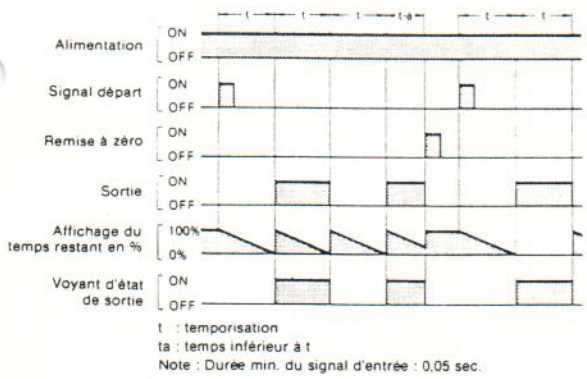

● Commande par tension d'alimentation

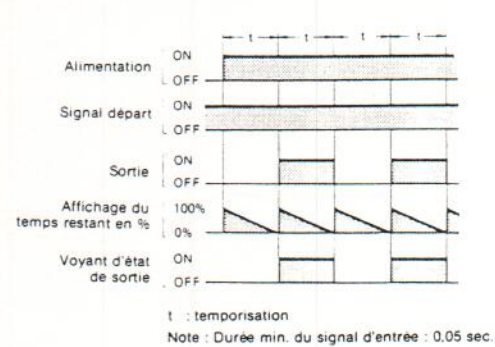

Mode C - Temporisation sur front montant / front descendant (type 1)

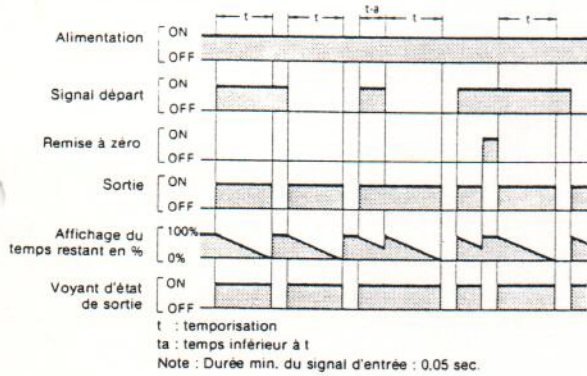

Mode D - Temporisation à partir d'un front descendant (type 1)

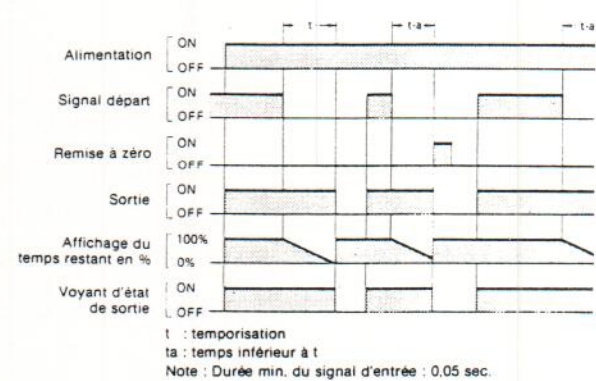

Mode E - Temporisation à la mise sous tension (par signal)

● Commande par signal

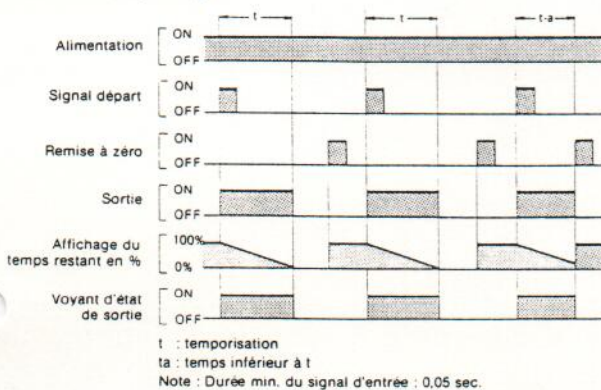

● Commande par tension d'alimentation

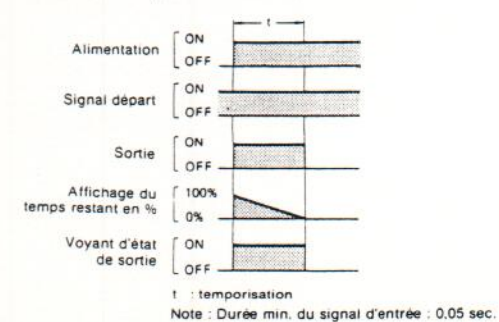

Huit modes de fonctionnement

Mode F - Clignotant une seule période

● Commande par signal

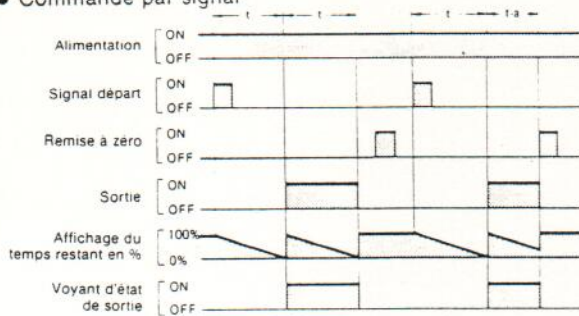

t : temporisation
 ta : temps inférieur à t
 Note : Durée min. du signal d'entrée : 0,05 sec.

● Commande par tension d'alimentation

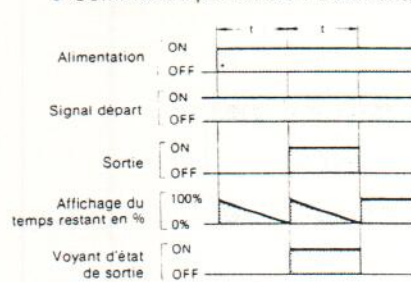

t : temporisation
 ta : temps inférieur à t
 Note : Durée min. du signal d'entrée : 0,05 sec.

Mode G - Temporisation sur front montant / front descendant (type 2)

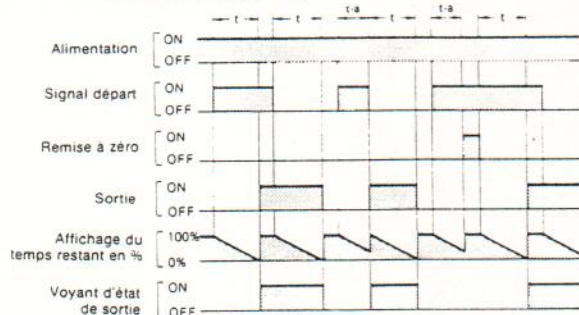

t : temporisation
 ta : temps inférieur à t
 Note : Durée min. du signal d'entrée : 0,05 sec.

Mode H - Temporisation à partir d'un front descendant (type 2)

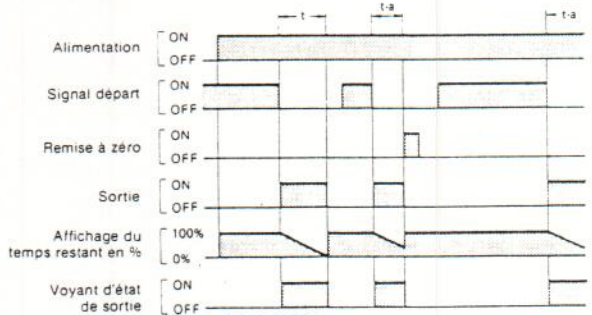

t : temporisation
 ta : temps inférieur à t
 Note : Durée min. du signal d'entrée : 0,05 sec.

Branchements

● Commande par contacts

Relier l'entrée départ aux bornes 3 et 6, l'entrée remise à zéro aux bornes 3 et 7, l'entrée PORTE aux bornes 3 et 5 et l'entrée TEST aux bornes 3 et 4.

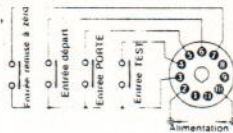

Utiliser des contacts plaqués or de haute fiabilité - la résistance doit être de 1 kΩ max et la tension résiduelle de 1 V max.

● Commande par signaux statiques

Relier l'entrée départ aux bornes 3 et 6, l'entrée remise à zéro aux bornes 3 et 7, l'entrée PORTE aux bornes 3 et 5 et l'entrée TEST aux bornes 3 et 4.

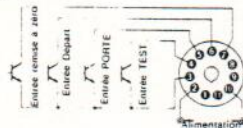

● Retard à la mise en tension

Caractéristiques du transistor :

V_{CE0} = 20 V min

V_{CE(S)} = 1 V max.

I_C = 50 mA min.

I_{CBO} = 0,5 μA max.

Lorsque le transistor est sur ON, la résistance est de 1 kΩ max, la tension résiduelle de 1 V max.

Lorsque le transistor est sur OFF, la résistance est de 200 kΩ min.

Exemple :

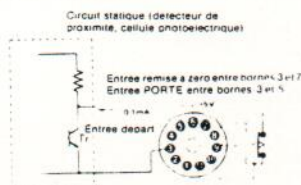

● Sortie

La minuterie H3CA possède un inverseur temporisé (8-9-11)

Entrée PORTE / fonction TEST

Comment utiliser l'entrée PORTE

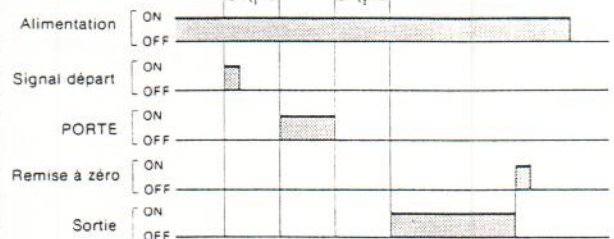

Exemple en mode A

Comment utiliser la fonction TEST

En cas de test durant une temporisation, le temps restant à compter sera 0 et la minuterie passera à l'étape suivante.

● Retard à la mise sous tension

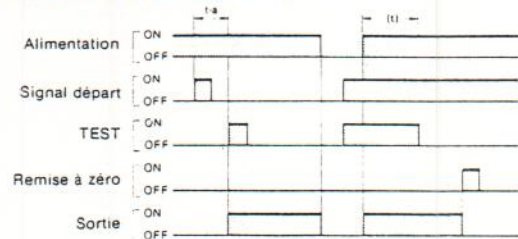

t : temporisation
 ta : temps inférieur à t

● Clignotant

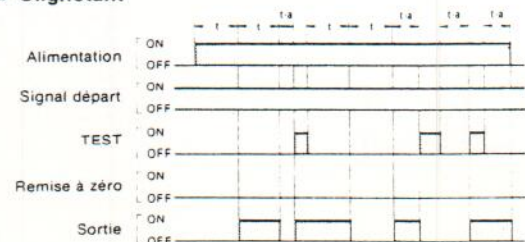

t : temporisation
 ta : temps inférieur à t

Socles

P2CF-11 - Socle pour montage sur rail DIN en surface (cosses à vis)

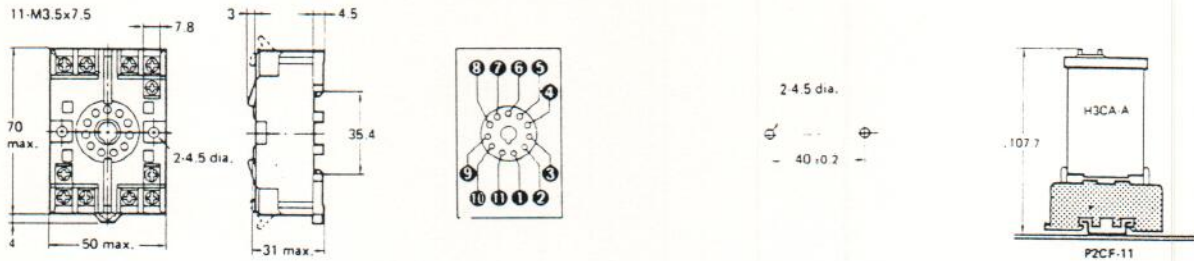

PL11 - Socle pour branchements arrière (cosses à souder)

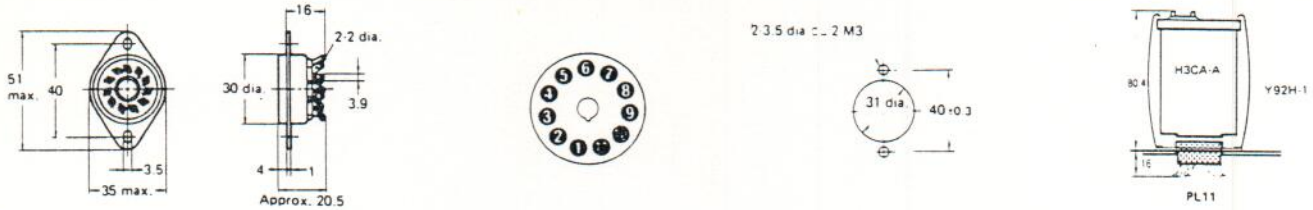

P3G-11 - Socle pour un montage encastré (bornes à vis)

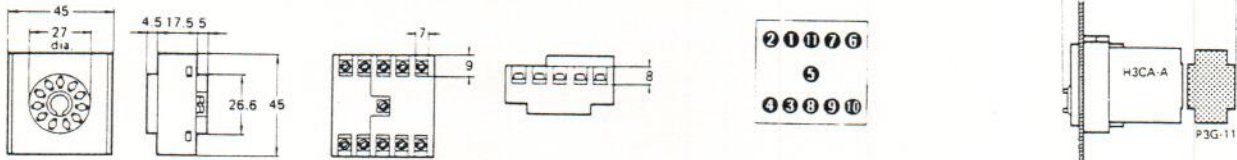

Accessoires

1. Adaptateur pour un montage encastré 48 x 48 mm. Type Y92F-30.

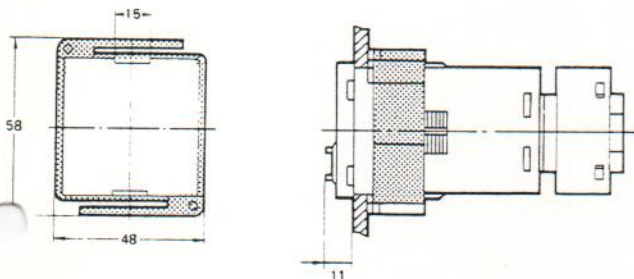

2. Capot protecteur

Un capot protecteur est disponible (modèle Y92A - 48B) pour protéger la face avant contre la poussière, les saletés et les gouttes d'eau, ainsi que des modifications accidentelles de la temporisation.

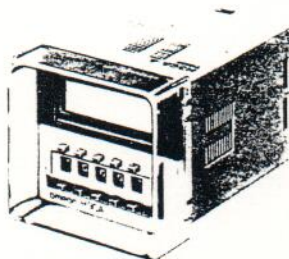

Y92A-48B

Conseils d'utilisation

1. Comment changer le mode de fonctionnement.

En actionnant le bouton poussoir situé en face avant, on obtient le mode de fonctionnement désiré (A, B, C, D, E, F, G et H).

2. Comment changer l'unité de temps et la plage de temporisation

En actionnant les boutons poussoirs situés en face avant on obtient l'unité de temps et la plage de temporisation désirées.

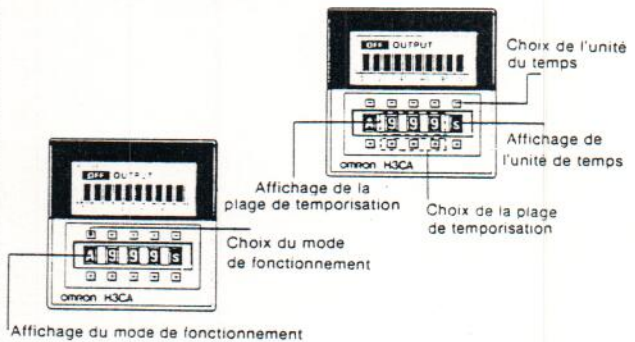

Unités de temps et plages de temporisation

Unités de temps	Plages de temporisation
0.1 s	0.1 99.9 s
s	1 999 s
0.1 m	0.1 99.9 m
m	1 999 m
0.1 h	0.1 99.9 h
h	1 999 h
10 h	10 9990 h

Attention : Couper l'alimentation. La minuterie pourrait être endommagée si la gamme de temporisation ou le mode de fonctionnement étaient modifiés pendant que la minuterie est sous tension. Afficher 000 provoquerait une temporisation infinie.

Unthreaded type

CAPACITIVE PROXIMITY SWITCH

Model **E2K**

Capacitive Type Capable of Detecting Nonmetallic Target as well as Metallic Target

FEATURES

- Detects metallic and nonmetallic targets (glass, lumber, water, oil, plastic, etc.) without direct contact with targets
- Permits indirect detection of targets buried in a nonmetallic wall or those placed in a nonmetallic container
- Loads of 200mA max. can be switched at 90 to 250V for AC switching type and at 10 to 40V for DC switching type
- For the threaded type and flat type, see the pages following the "Unthreaded type"

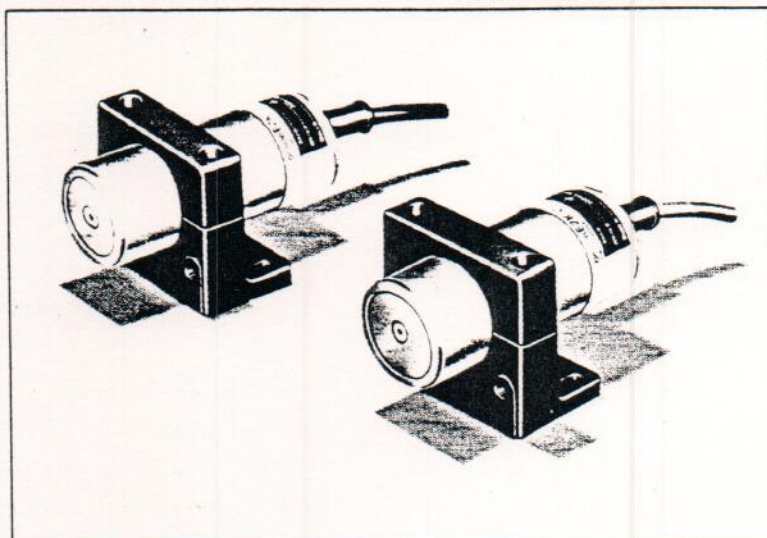

AVAILABLE TYPES

Detecting distance		3 to 25mm (variable)	
Output form		N.O.	N.C.
DC switching type	NPN	E2K-C25ME1	E2K-C25ME2
	PNP	E2K-C25MF1	E2K-C25MF2
AC switching type		E2K-C25MY1	E2K-C25MY2

OMRON

SPECIFICATIONS

RATINGS

Item	Type	E2K-C25MY1 E2K-C25MY2	E2K-C25ME1, E2K-C25MF1 E2K-C25ME2, E2K-C25MF2
Supply voltage		90 to 250 VAC, 50/60Hz	10 to 40 VDC (permissible ripple*: 10% max. (P-P))
Current consumption		1mA max. (at 100 VAC, 50/60Hz) 2mA max. (at 200 VAC, 50/60Hz) (under no load)	10mA max. (at 12 VDC) 15mA max. (at 24 VDC)
Target		Conductors and dielectrics	
Detecting distance (with standard target)		3 to 25mm (with grounded metal: 50x50x1t)	
Differential travel		15% max. of detecting distance (when adjusted to 25mm±10% with standard target)	
Response frequency		10Hz min.	70Hz min.
Control output		5 to 200mA AC, p.f.=1 (resistive load) (at -25 to +70°C)	200mA max.

NOTE: * Use of full-wave rectified 24 VDC ±10% (mean value) is also possible.

OUTPUT STAGE CIRCUIT DIAGRAMS

E2K-C25MY1 (N.O.)
E2K-C25MY2 (N.C.)

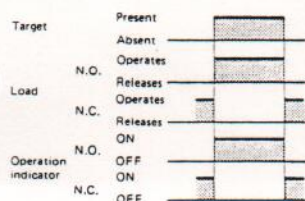
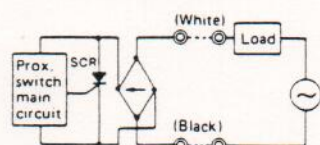

E2K-C25ME1 (N.O.)
E2K-C25ME2 (N.C.)

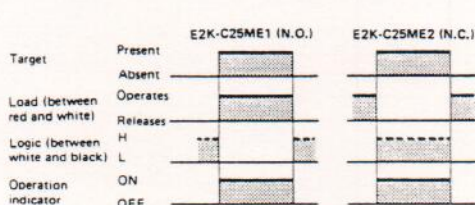
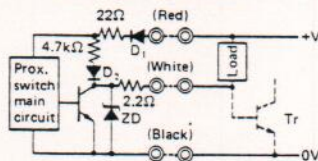

E2K-C25MF1 (N.O.)
E2K-C25MF2 (N.C.)

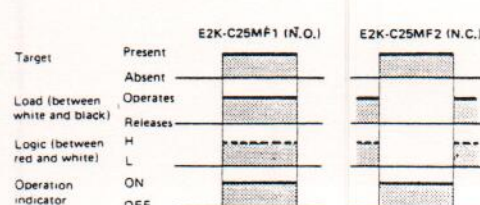
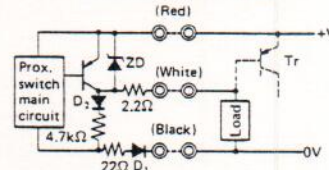

CHARACTERISTICS

Item	Type	E2K-C25MY1 E2K-C25MY2	E2K-C25ME1, E2K-C25MF1 E2K-C25ME2, E2K-C25MF2
Variation due to temperature fluctuation		Within a temperature range of -10 to +55°C ±15% max. of detecting distance at 20°C (with standard target) Within a temperature range of -25 to +70°C ±25% max. of detecting distance at 20°C (with standard target)	
Variation due to voltage fluctuation		±2% max. of detecting distance when operated at 100 VAC +20%, -10%, or 200 VAC ±20%.	±2% max. of detecting distance when operated at 12 VDC ±15% or 24 VDC ±15%.
Leakage current		Refer to "Leakage current characteristics" (AC switching type only)	
Residual voltage		Refer to "Output Stage Circuit Diagram", or "Characteristic Data".	
Insulation resistance		50MΩ min. (at 500 VDC)	
Dielectric strength		1,500 VAC, 50/60Hz for 1 minute	1,000 VAC, 50/60Hz for 1 minute
Vibration		10 to 55Hz; 1.5mm double amplitude	
Shock		500m/sec ² (approx. 50G's)	
Degree of protection		Water-resistant type (JIS C0920), IP-66 (IEC 144), NEMA types 1, 4, 12, 13	
Ambient temperature		Operating: -25 to +70°C	
Humidity		35 to 95% RH	
Weight		Approx. 200g (with standard 2m cable)	

CHARACTERISTIC DATA

Operating Range Diagram
Typical example: E2K-C25MY1

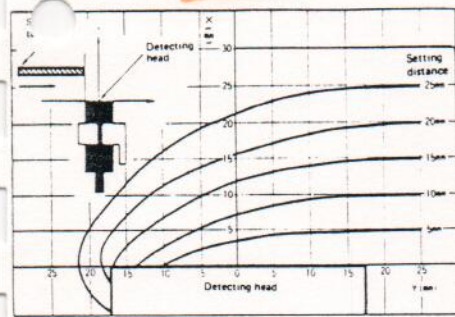

Leakage Current Characteristics
Typical example: E2K-C25MY1

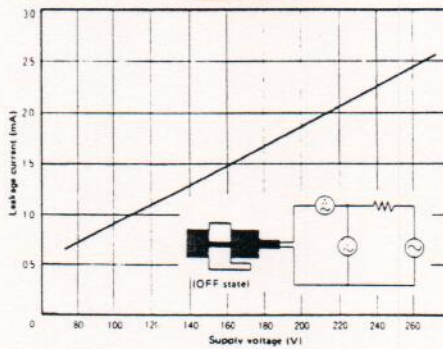

Detecting Distance vs. Size and Material of Target

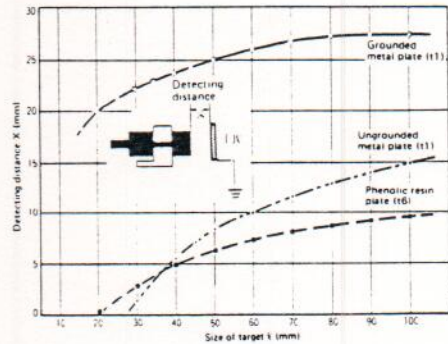

Residual Load Voltage Characteristics
Typical example: E2K-C25MY1, 100 VAC

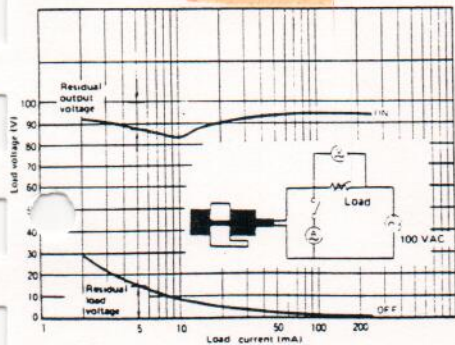

Residual Load Voltage Characteristics
Typical example: E2K-C25MY1, 200 VAC

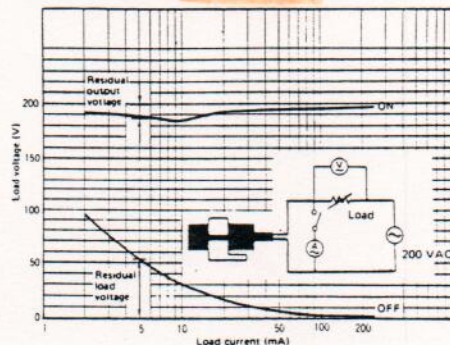

Residual Load Voltage Characteristics
Typical example: E2K-C25ME1

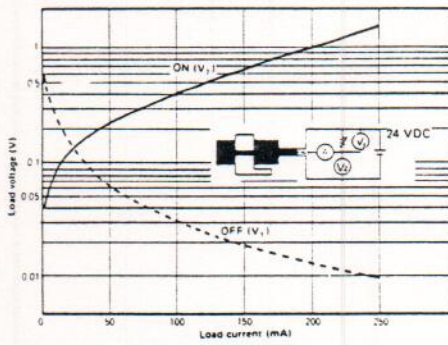

NOTE: If the load current is less than 10mA, the residual voltage of the load increases when the proximity switch is in the OFF state. In this case, connect a bleeder resistor in parallel with the load and allow a current of more than 10mA to flow through the load.

Approved by standard:
UL (File No. E61312)
E2K-C25E(F) series only

$$R \leq \frac{V_L}{10 - I} \quad (\text{K}\Omega)$$

$$P > \frac{V_L^2}{R} \quad (\text{mW})$$

P: Wattage of bleeder resistor
I: Load current (mA)

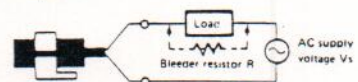

DIMENSIONS

● PROXIMITY SWITCH (E2K-C25□)

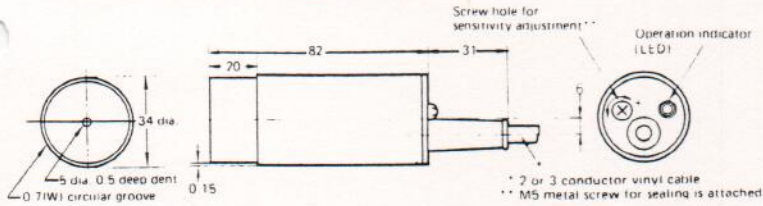

E2K-C25MY1	2/45/0.12 dia. (0.5mm ²)
E2K-C25MY2	Standard length: 2m OD: 6mm
E2K-C25ME1	3/45/0.12 dia. (0.5mm ²)
E2K-C25ME2	Standard length: 2m OD: 6mm
E2K-C25MF1	
E2K-C25MF2	

NOTE: Extendable cable length is 200m max. (independently through metallic conduit)

● L-SHAPED MOUNTING BRACKET (supplied with the switch)

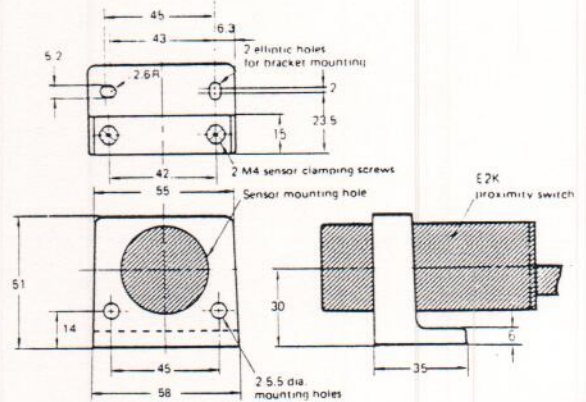

CONNECTIONS

● AC SWITCHING TYPE (E2K-C25MY1, E2K-C25MY2)

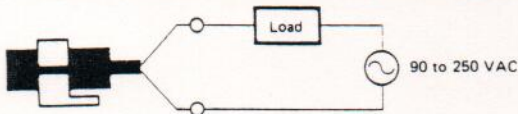

● DC SWITCHING TYPE

Single unit control (E2K-C25ME2, E2K-C25MF1)

NOTE: E2K-C25ME1, MF2 may also be used. In this case, however, the load operation is reversed (i.e., the load releases when the object is present).

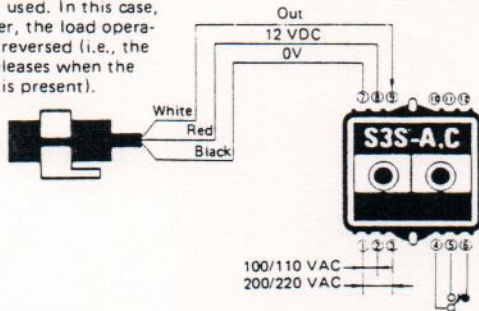

Single unit control (E2K-C25ME1, E2K-C25ME2)

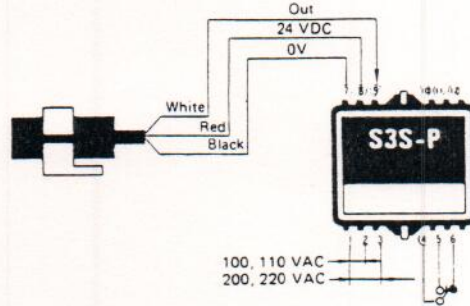

2-unit control (E2K-C25ME2)

Use a pair of Type E2K-C25ME2 proximity switches for normal 2-unit control.

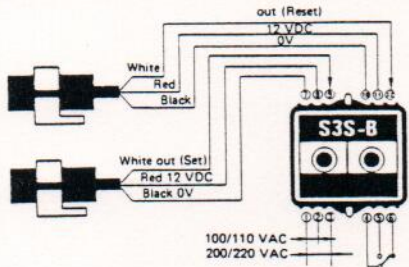

NOTE: For detailed information on Model S3S controller unit, refer to the separately published catalog of the controller unit. S3S also has a UL recognized version (rated at 120/240 VAC).

Water Supply/Drainage Control by Directly Detect a Water Level

For 2-unit control to directly detect a water level, use Type E2K-C25ME1 and Type E2K-C25ME2 proximity switches together as a pair connected as shown in the figure below.

For water supply control by directly detecting the water level

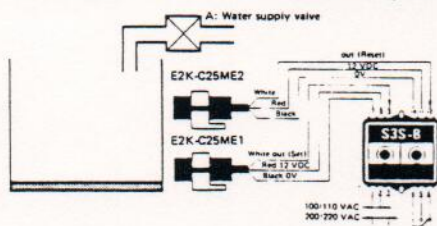

Timing chart (Connect water supply valve A to the N.O. contact of controller unit Type S3S-B.)

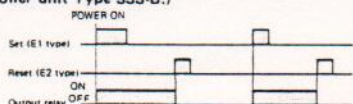

For water drainage control by directly detecting the water level

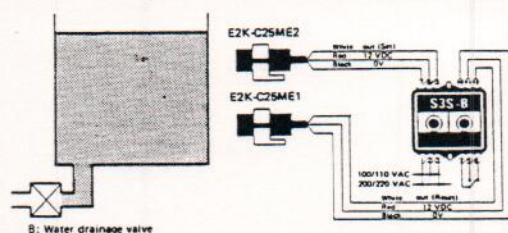

Timing chart (Connect the drain valve to the N.O. contact of controller unit Type S3S-B.)

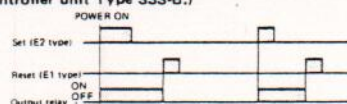

HINTS ON CORRECT USE

INFLUENCE OF SURROUNDING METALS

When mounting a proximity switch, be sure to provide a minimum distance of 80mm from the surrounding metallic object, to prevent the switch from being affected by metallic objects other than the target.

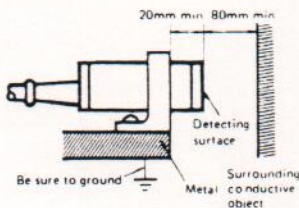

When mounting the switch with an exclusive L-shaped mounting bracket, be sure to provide a distance of 20mm or more between the face of the detecting head and the mounting bracket.

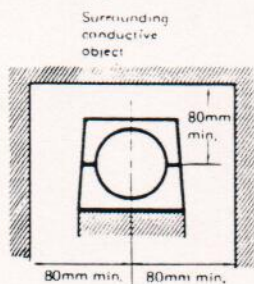

MUTUAL INTERFERENCE

Be sure to space the two switches at a distance greater than 100mm to prevent mutual interference.

Opposed mounting

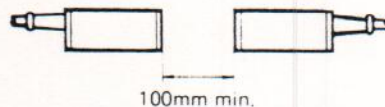

Parallel mounting

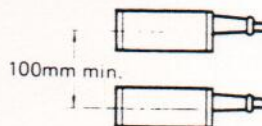

SENSITIVITY ADJUSTMENT

1. N.O. type (E2K-C25□1)

Unscrews the potentiometer and turn it for sensitivity adjustment with the screwdriver supplied as an accessory.

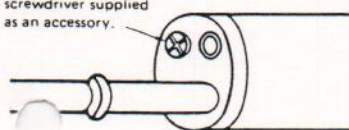

- Without any target in front of the detecting head, turn the potentiometer clockwise until the proximity switch turns ON. Stop the potentiometer at this point.

Potentiometer



Stop when the switch turns ON

- With a target in front of the detecting head, turn the potentiometer counterclockwise from the ON position stated in ① above, until the proximity switch turns OFF. Stop the potentiometer at this point.

Potentiometer



Stop when the switch turns OFF

- Check to see that the difference between the ON point in ① and the OFF point in ② is more than one and a half turns by the number of meter rotations for adjustment. If the difference is more than one and a half turns, the proximity switch performs stable detecting operation.

- Set the potentiometer at the center between the ON and OFF points.

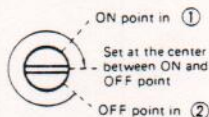

- If the interval between the proximity switch and a target is not constant, perform adjustment operation ① above when the target is at the closest position to the switch and adjustment operation ② above when the target is at the farthest position from the switch.

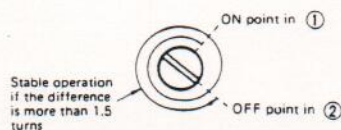

2. N.C type (E2K-C25□2)

Sensitivity adjustment procedure for N.C. type proximity switches are the same as the N.O. type, with the exception that ON and OFF operations of the proximity switch and ON and OFF points in the above procedure are to exact reverse.

General Information on AC Switching Type

Load selection and wiring

(1) Connection to power source

Be sure to connect the proximity switch to the power source through a load, or direct connection of the switch may cause damage to the internal elements of the switch.

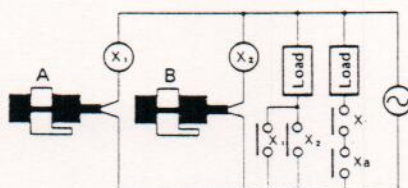
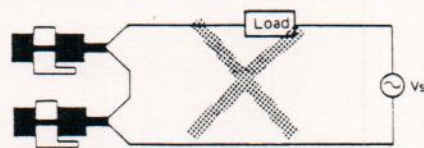

(2) Series and parallel connections of proximity switches

In general, proximity switches cannot be employed in series or parallel connection. If such an arrangement is necessary, use of series- or parallel-connected switches through relays is recommended.

Use of metallic conduit

If a high voltage or power line runs near the proximity switch cable, be sure to wire the switch cable through a metallic conduit to prevent the switch from malfunctioning or damage.

Surge protection

The proximity switch is provided with a surge suppressor circuit. However, if any large surge generating source (e.g., motor, welding machine) exists in the vicinity of the proximity switch, it is recommended to insert such a surge suppressor as a varistor, into the surge generating source.